

KitchenAid®

WORSTVULAPPARAAT
INSTRUCTIES EN RECEPTEN

SAUSAGE STUFFER
INSTRUCTIONS AND RECIPES

ACCESSOIRE POUR FARCIR LES SAUCISSES
MODE D'EMPLOI ET RECETTES

WURSTFÜLLHORN
BEDIENUNGSANLEITUNG UND REZEPTE

SET PER INSACCARE
ISTRUZIONI PER L'USO E RICETTE

EMBUTIDOR DE SALCHICHAS
INSTRUCCIONES Y RECETAS

KORVHORN
INSTRUKTIONER OCH RECEPT

PØLSEHORN
BRUKSANVISNING OG OPPSKRIFTIR

MAKKARAN-TÄYTTÖPUTKILO
KÄYTTÖOHJEET JA RESEPTIT

PØLSEHORN
INSTRUKTIONER OG OPSKRIFTER

FUNIL PARA SALSICHAS
INSTRUÇÕES E RECEITAS

KRANSAKÖKU-OG PYLSUGERÐASTÚTAR
LEIÐBEININGAR OG UPPSKRIFTIR

ΕΞΑΡΤΗΜΑ ΠΑΡΑΣΚΕΥΗΣ ΛΟΥΚΑΝΙΚΩΝ
ΟΔΗΓΙΕΣ ΚΑΙ ΣΥΝΤΑΓΕΣ

English



Model 5SSA
Sausage Stuffer
Designed exclusively for use with all
KitchenAid® Household Stand Mixers.

Table of Contents

Stand Mixer Attachment Safety.....	1
Important Safeguards.....	1
To Attach Stand Mixer Attachment.....	2
Before Attaching Stand Mixer Attachment.....	2
Food Grinder* Attachment.....	2
To Assemble Food Grinder Attachment.....	2
To Use Food Grinder Attachment.....	3
To Clean Food Grinder Attachment.....	3
Sausage Stuffer Attachment.....	4
To Assemble Sausage Stuffer Attachment.....	4
To Use Sausage Stuffer Attachment.....	4
To Form Smaller Links.....	5
To Clean Sausage Stuffer Attachment.....	5
Mild Breakfast Sausage.....	5
KitchenAid® Household Stand Mixer Attachment Warranty.....	6
Service Centers.....	6
Customer Service.....	6

* Food Grinder Attachment sold separately.

Stand Mixer Attachment Safety

Your safety and the safety of others are very important.

We have provided many important safety messages in this manual and on your appliance. Always read and obey all safety messages.



This is the safety alert symbol.

This symbol alerts you to potential hazards that can kill or hurt you and others.

All safety messages will follow the safety alert symbol and either the word "DANGER" or "WARNING." These words mean:

⚠ DANGER

You can be killed or seriously injured if you don't immediately follow instructions.

⚠ WARNING

You can be killed or seriously injured if you don't follow instructions.

All safety messages will tell you what the potential hazard is, tell you how to reduce the chance of injury, and tell you what can happen if the instructions are not followed.

IMPORTANT SAFEGUARDS

When using electrical appliances, basic safety precautions should always be followed including the following:

1. Read all instructions.
2. To protect against risk of electrical shock, do not put mixer in water or other liquid.
3. The appliance is not intended for use by young children or infirm persons without supervision.
4. Unplug from outlet when not in use, before putting on or taking off parts, and before cleaning.
5. Avoid contacting moving parts. Keep fingers out of discharge opening.
6. Do not operate the mixer with a damaged cord or plug or after the mixer malfunctions, or is dropped or damaged in any manner. Return the mixer to the nearest Authorized Service Center for examination, repair or electrical or mechanical adjustment.
7. The use of attachments not recommended or sold by KitchenAid may cause fire, electric shock or injury.
8. Do not use the mixer outdoors.
9. Do not let the cord hang over the edge of table or counter.
10. Never feed food by hand. Always use combination food pusher/wrench.
11. Blades are sharp. Handle carefully.
12. This product is designed for household use only.

SAVE THESE INSTRUCTIONS

To Attach Stand Mixer Attachment

Before Attaching Stand Mixer Attachment

1. Turn Stand Mixer speed control to "0" (OFF).
2. Unplug mixer or disconnect power.
3. Depending on which type of hub you have, either flip up hinged cover or loosen the attachment knob (A) by turning it counterclockwise and remove attachment hub cover.
4. Insert the attachment shaft housing (B) into the attachment hub (C) making certain that attachment power shaft fits into square hub socket.
5. It may be necessary to rotate the attachment back and forth. When the

- attachment is in proper position, the pin on the attachment housing will fit into the notch on the hub rim.
6. Tighten the attachment knob by turning it clockwise until the attachment is completely secured to mixer.

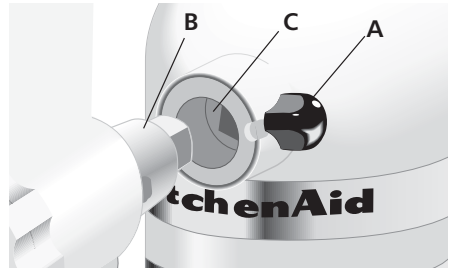

Food Grinder* Attachment

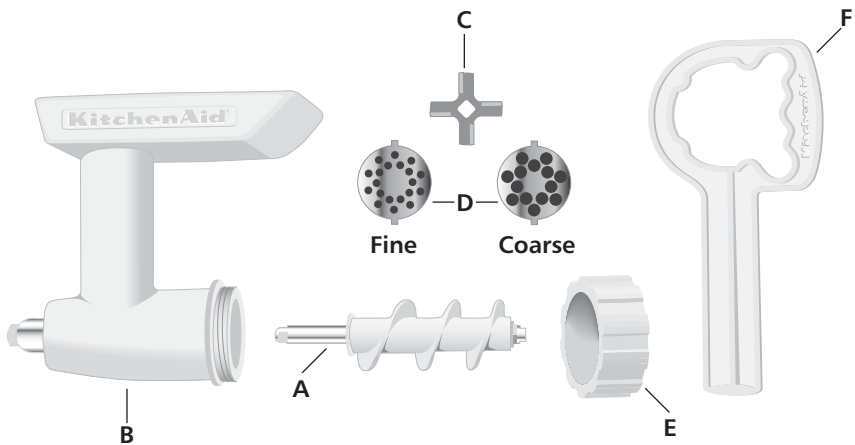

To Assemble Food Grinder Attachment

1. Insert the grind worm (A) into the grinder body (B).
2. Place the knife (C) over the square shank at the exposed end of the grind worm.
3. Place grinding plate (D) over the knife, matching the tabs of the plate with the notches of the grinder body.
4. Place ring (E) on grinder body, turning by hand until secured but not tightened.

NOTE: The combination food pusher/wrench (F) is used for removal of ring (E) only. Do not use it to tighten ring (E).

NOTE: Use Sausage Stuffer (model SSA) with Food Grinder (model FGA).

* Food Grinder Attachment sold separately.

Food Grinder* Attachment

To Use Food Grinder Attachment

WARNING



Rotating Blade Hazard

Always use food pusher.

Keep fingers out of openings.

Keep away from children.

Failure to do so can result in amputation or cuts.

1. Cut food into small strips or pieces and feed them into hopper. Meat should be cut into long narrow strips.
2. Turn mixer to Speed 4 and feed food into hopper using combination food pusher/wrench.

NOTE: Liquid may appear in hopper when processing large amounts of high moisture foods such as tomatoes or grapes. To drain liquid, continue to operate mixer. To avoid damage to mixer, do not process additional food until liquid has drained from hopper.



Coarse Plate – Use for grinding raw or cooked meats, firm vegetables, dried fruits and cheese.



Fine Plate – Use for grinding raw meat, cooked meats for spreads and breadcrumbs.

Grinding Meat – For better mix and more tender results, grind beef twice. Best texture results from grinding very cold or partially frozen meat. Fatty meats should be ground only once.

Grinding Bread – To grind bread for crumbs, be sure that bread is either oven dried thoroughly to remove all moisture, or not dried at all. Partially dried bread may jam the Food Grinder.

NOTE: Very hard, dense foods such as totally dried homemade bread should not be ground in the Food Grinder. Homemade bread should be ground fresh and then oven or air-dried.

To Loosen Ring – If ring is too tight to remove by hand, slip the combination food pusher/wrench over the grooves and turn counterclockwise.

NOTE: To avoid damage to the food grinder attachment, do not use combination food pusher/wrench to tighten ring to grinder body.

To Clean Food Grinder Attachment

First completely disassemble food grinder attachment.

The following parts are dishwasher safe:

- Grinder body
- Grinder worm
- Ring
- Combination food pusher/wrench

The following parts should be hand washed in warm, sudsy water and dried thoroughly:

- Knife
- Grinding plates

* Food Grinder Attachment sold separately.

Sausage Stuffer Attachment

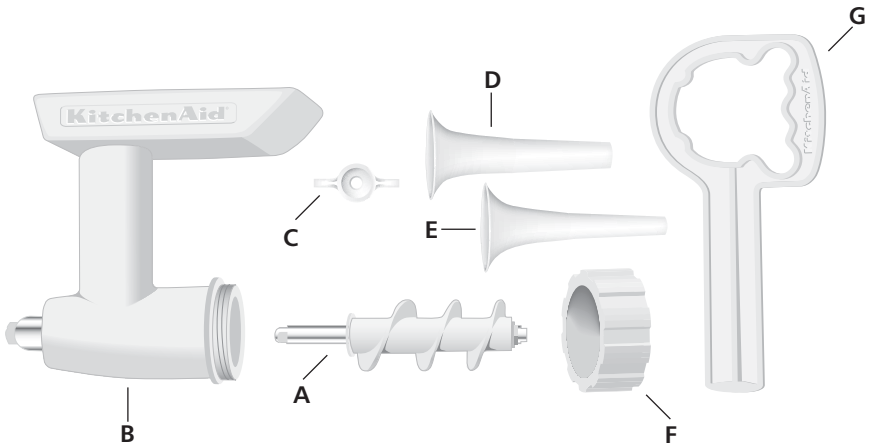

To Assemble Sausage Stuffer Attachment:

1. Insert grind worm (A) into the grinder body (B).
2. Place the retainer bar (C) over the square shank at the exposed end of the grind worm.
3. Insert desired Sausage Stuffer tube (D) or (E) in ring (F) and then screw onto grinder body, turning by hand until finger tight, but not over tightened.

NOTE: The combination food pusher/wrench (G) is used for removal of ring (F) only. Do not use it to tighten ring (F).

NOTE: Use Sausage Stuffer (model SSA) with Food Grinder (model FGA).

To Use Sausage Stuffer Attachment

! WARNING



Rotating Blade Hazard

Always use food pusher.

Keep fingers out of openings.

Keep away from children.

Failure to do so can result in amputation or cuts.

Use the small Sausage Stuffer tube (E) to make breakfast sausage with casings and the large Sausage Stuffer tube (D) to prepare Bratwurst, Italian or Polish sausage with casings or breakfast sausage without casings.

1. If using natural casings, it's recommended to first soak them in cold water for 30 minutes to remove excess salt, then rinse several times by running cold water through the entire length of casing.
2. Grease stuffer tube with shortening and slide, 3 to 4 feet (91 to 122 cm) of casing onto stuffer tube.
3. Tie the end of the casing with string to seal.
4. Turn mixer to Speed 4 and slowly feed ground meat mixture into hopper using the combination food pusher/wrench.
5. Hold the tied end of the casing in one hand and guide meat mixture as it fills casing.

NOTE: Do not pack meat mixture too tightly into casing; allow enough room to twist sausage into smaller links and for expansion during cooking. If an air pocket develops, pierce with a toothpick or skewer. To complete a recipe using several pounds of meat, it may be necessary to repack the Sausage Stuffer with casing several times to use all of the ground meat mixture.

Sausage Stuffer Attachment

To Form Smaller Links

To form smaller links, lay the entire length of sausage on a flat surface and twist filled casing several times at regular intervals. Fresh sausage may be stored 1 to 2 days in the refrigerator or up to 1 month in the freezer.

To Clean Sausage Stuffer Attachment

First completely disassemble sausage stuffer attachment.

The following parts are dishwasher safe:

- Retainer bar
- Sausage Stuffer tubes
- Grinder body
- Grinder worm
- Ring
- Combination food pusher/wrench

Mild Breakfast Sausage

- 3 pounds (1.5 kg) pork shoulder cut into 1-inch (2.5-cm) strips
- 1/4 cup (60 g) minced onion
- 4 teaspoons (20 g) sage
- 1/2 teaspoon (3 g) savory
- 4 teaspoons (20 g) salt
- 1 teaspoon (5 g) pepper
- 1/3 cup (80 g) chopped parsley
- 1/2 teaspoon (3 g) chervil
- 1/3 teaspoon (2 g) marjoram
- Dash allspice
- 2 tablespoons (30 ml) water
- 1 egg, beaten
- 1 tablespoon (15 g) shortening
- Natural or synthetic casings

Place pork on metal baking sheet and freeze 20 minutes. Combine onion, sage, savory, salt, pepper, parsley, chervil, marjoram, and allspice. Sprinkle mixture over pork.

Assemble and attach Food Grinder using coarse grinding plate. Turn to Speed 4 and grind pork into bowl. Add water and egg. Attach bowl and flat beater. Turn to Stir Speed and mix 1 minute.

Remove knife and coarse grinding plate from Food Grinder. Assemble and attach Sausage Stuffer. Grease Stuffer with shortening and slide casing on tightly. Tie off end of casing. Turn to Speed 4 and stuff pork mixture into casings. Twist sausage into smaller links and refrigerate or freeze until ready to use.

Yield: 3 pounds (1.5 kg) sausage.

KitchenAid® Household Stand Mixer Attachment Warranty

English

Length of Warranty:	KitchenAid Will Pay For:	KitchenAid Will Not Pay For:
<p>Europe & Australia: Two Year Full Warranty from date of purchase.</p> <p>Other: One Year Full Warranty from date of purchase.</p>	<p>Replacement parts and repair labor costs to correct defects in materials or workmanship. Service must be provided by an Authorized KitchenAid Service Center.</p>	<p>A. Repairs when Sausage Stuffer is used for operations other than normal household food preparation.</p> <p>B. Damage resulting from accident, alterations, misuse, abuse, or installation/operation not in accordance with local electrical codes.</p>

KITCHENAID DOES NOT ASSUME ANY RESPONSIBILITY FOR INDIRECT DAMAGES.

Service Centers

All service should be handled locally by an Authorized KitchenAid Service Center. Contact the dealer from whom the unit was purchased to obtain the name of the nearest Authorized KitchenAid Service Center.

In the U.K.:
Call: 0845 6011 287

In Ireland:
M.X. ELECTRIC
Service Department
25 Alymer Crescent
Kilcock, CO.KILDARE
Call: 1 679 2398/87 2581574
Fax: 1 628 4368

In Australia:
Call: 1800 990 990

In New Zealand:
Call: 0800 881 200

Customer Service

In U.K. & Ireland: Tollfree number 00800 38104026

Address: KitchenAid Europa, Inc.
PO BOX 19
B-2018 ANTWERP 11
BELGIUM

www.KitchenAid.com
www.KitchenAid.co.uk



FOR THE WAY IT'S MADE.™

® Registered Trademark of KitchenAid, U.S.A.

™ Trademark of KitchenAid, U.S.A.

The shape of the stand mixer is a trademark of KitchenAid, U.S.A.

© 2007. All rights reserved.

Specifications subject to change without notice.